

Overall dimensions

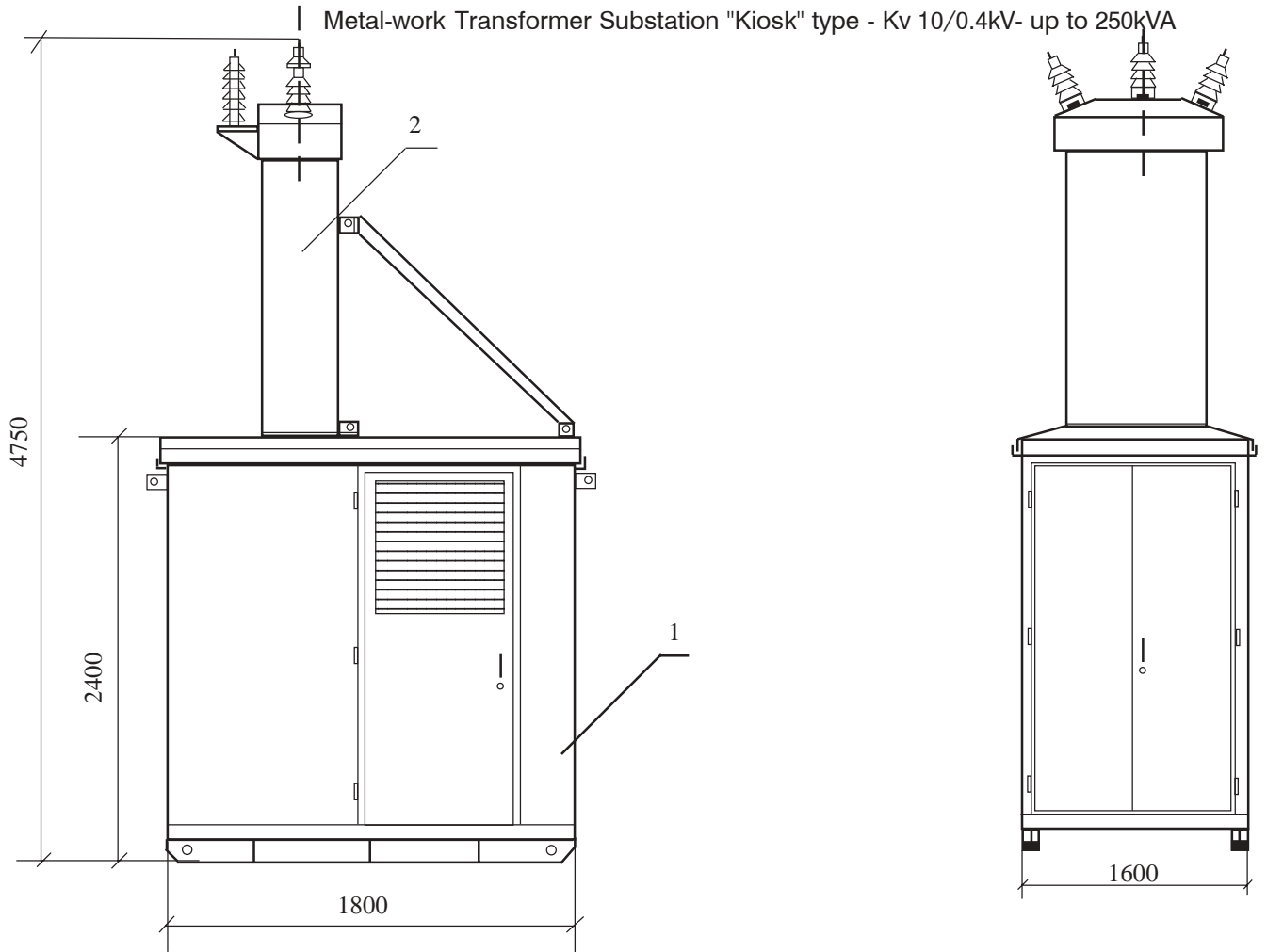

1. Transformer Substation "Kiosk" type
- Kv 10/0.4kV- up to 250kVA
2. Tower wit bushing insulators type ПрБ
3. Power Oil-Immerced Transformer
- 10/0.4kV- up to 250kVA
/ Transformer Compartment/
4. Distribution Switchboard L.V. 0,4/0,23 kV
5. M.V. Switchboard 10(20)kV
Income and Transformer Protection Panel with Fuses
type CEF 10 kV/ 6...16A

Area - 2.88 sq.m.
Weight - 1 450 kg

1. The unit is delivered completely equipped
2. The unit meets the requirements of IEC 298
3. Protection Degree:

Transformer Compartment	- IP 33
H.V. and L.V. Compartment	- IP 44

Metal-work Transformer Substation "Kiosk" type - Kv 10/0.4 kV- up to 250kVA

Transport dimensions

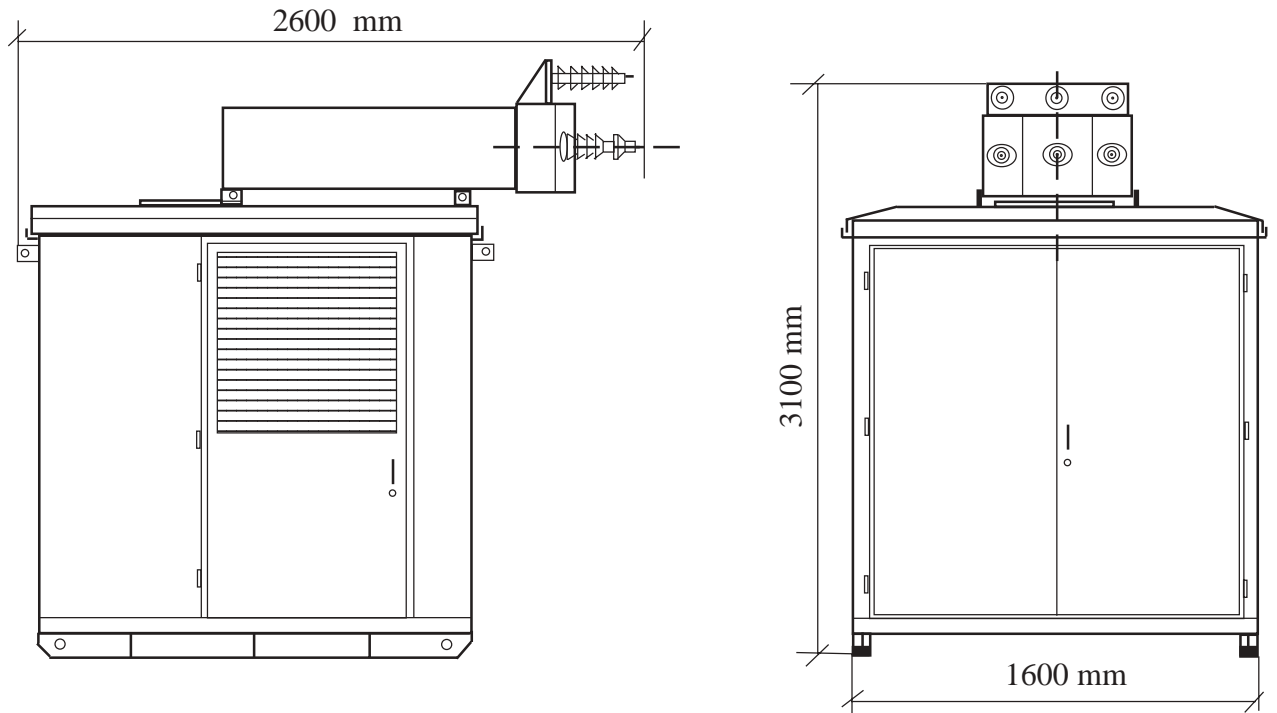

Packaged dimensions

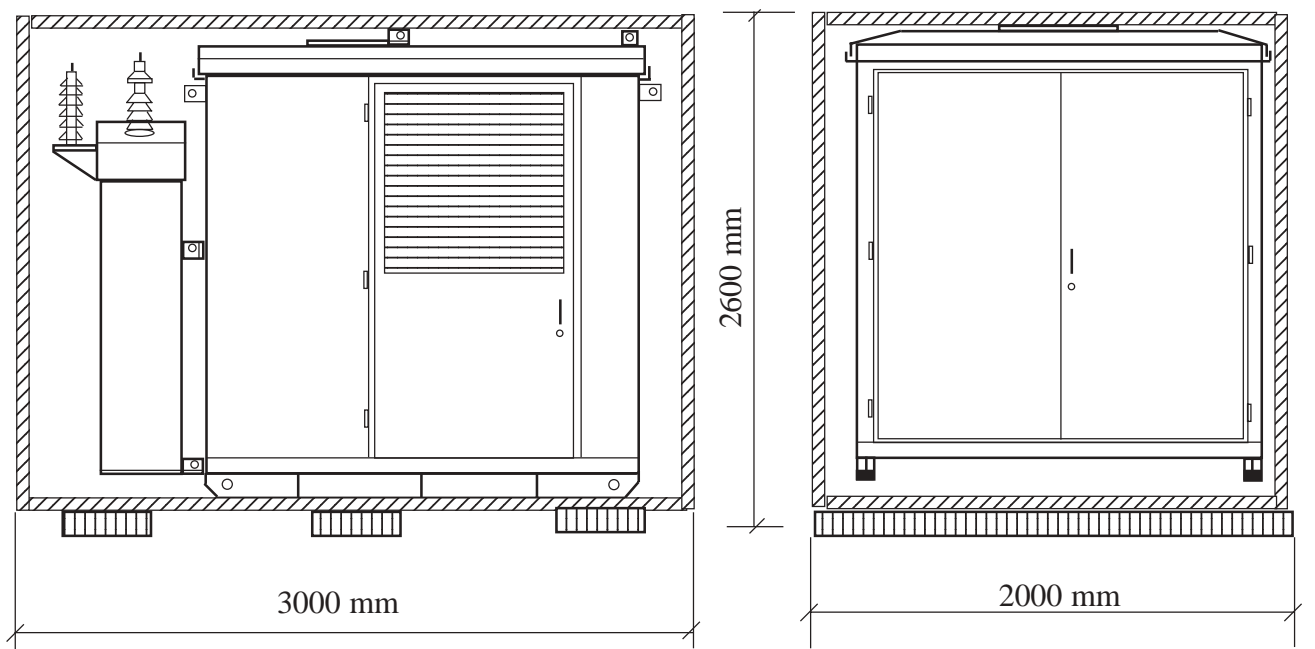

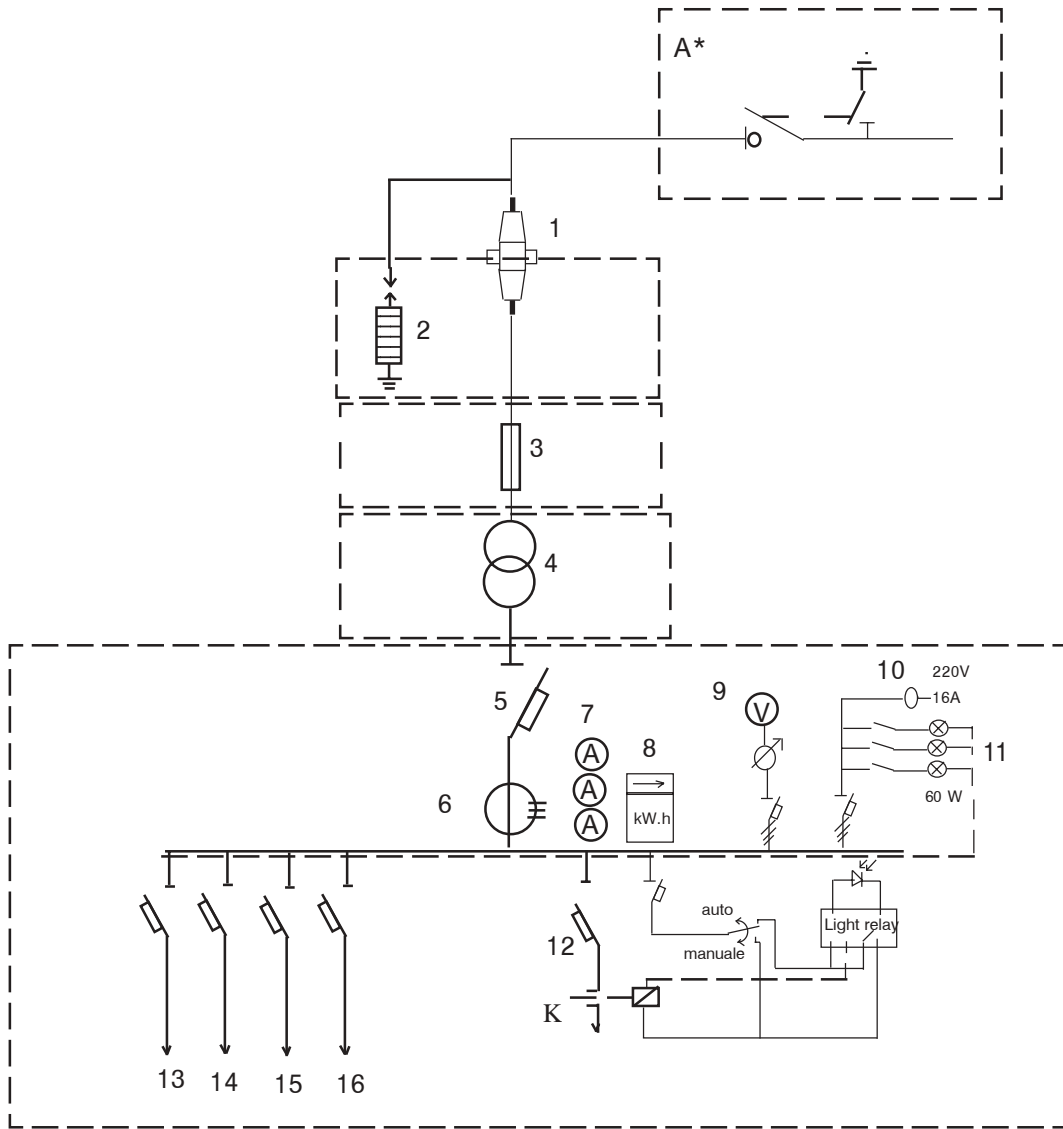

A* Isolator for andoor operation for 10 kV type ROM 10 kV,400A wit 3ph earting blades ZNO 10kV,630A and motor-operated mehanism ZMR 800 - 1 pcs.

Overall dimensions

Metal-work Transformer Substation "Kiosk" type - Kv 20/0.4kV- up to 630kVA

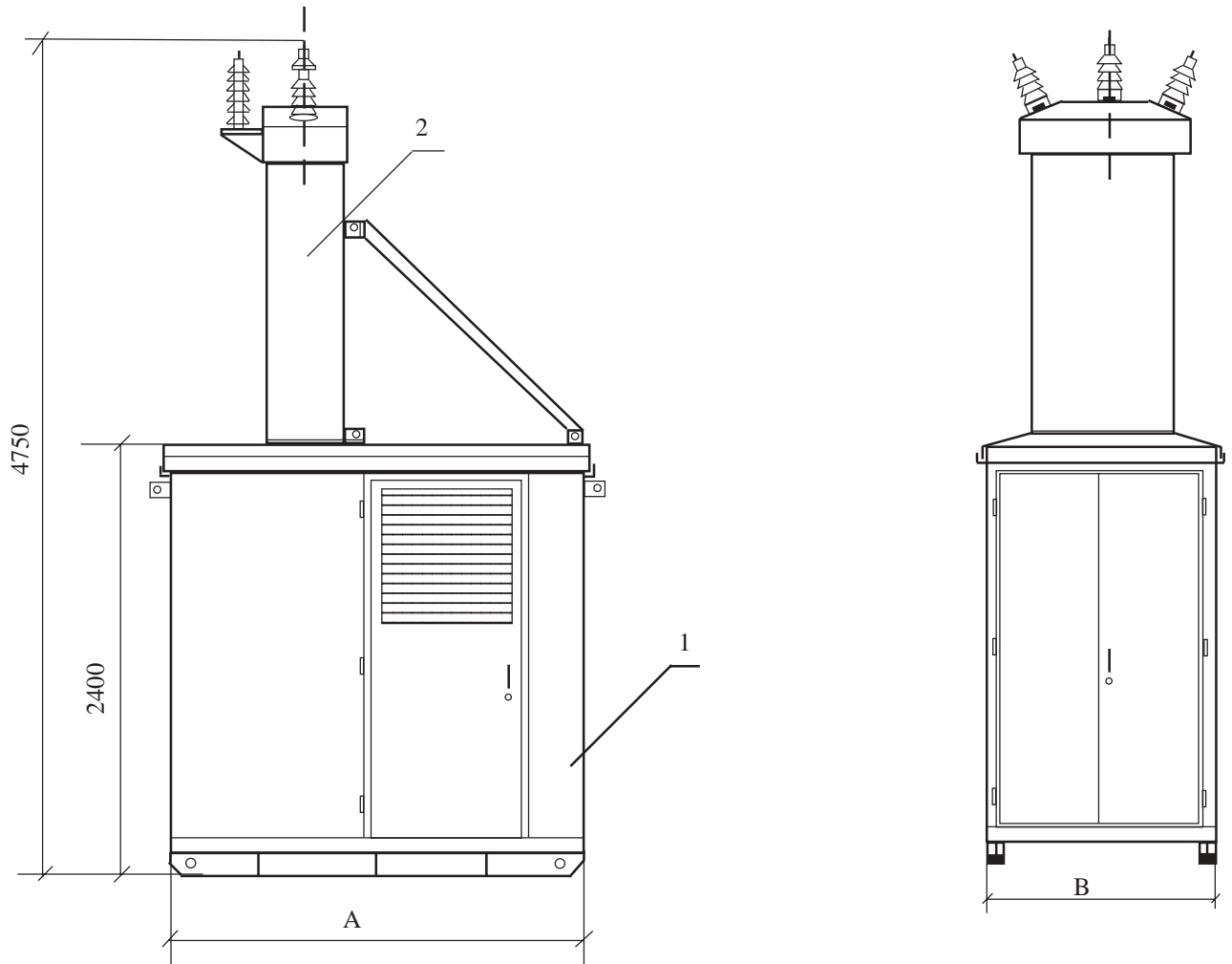

КТП Kv 20/0.4 kV	A	B
63;100;160;250 kVA	2 300	1 600
400 and 630 kVA	2 700	2 000

1. Transformer Substation "Kiosk" type
- Kv 20/0.4kV- up to 630kVA
2. Tower wit bushing insulators type ПрБ
3. Power Oil-Immerced Transformer
- 20/0.4kV- up to 630kVA
/ Transformer Compartment/
4. Distribution Switchboard L.V. 0,4/0,23 kV
5. M.V. Switchboard 20kV :
 - 5.1 Income and Transformer Protection Panel
Disconnecter type PММ_{3HK} with Fuses type
ВПМ20 kV/ 6...40A
 - 5.2 Income and Transformer Protection Panel
Switch disconnecter type NAL F 20/400 RE with
Fuses type CEF 20 kV/ 6...40A

Area - 3.68/5.4 sq.m.

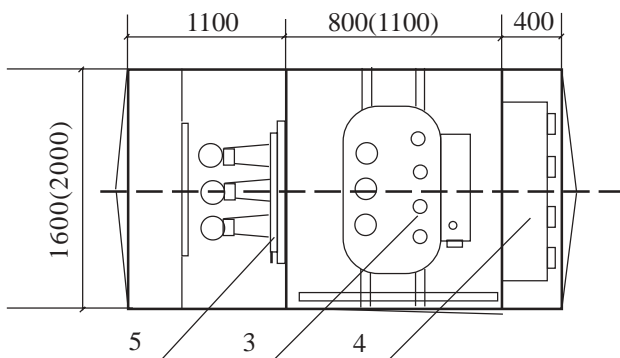

1. The unit is delivered completely equipped
2. The unit meets the requirements of IEC 298
3. Protection Degree:
 - Transformer Compartment - IP 33
 - H.V. and L.V. Compartment - IP 44

Metal-work Transformer Substation "Kiosk" type - Kv 20/0.4 kV- up to 630kVA

Transport dimensions

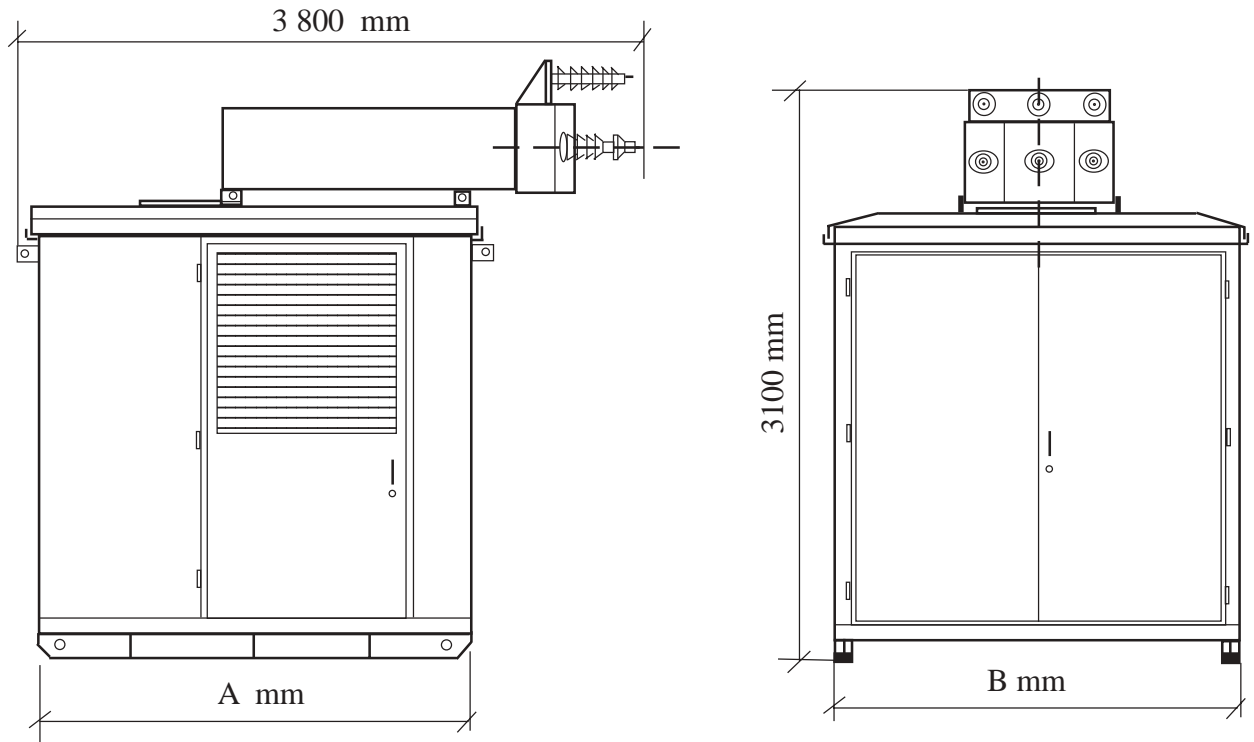

КТП Kv 20/0.4 kV	A	B
63;100;160;250 kVA	2 300	1 600
400 and 630 kVA	2 700	2 000

Packaged dimensions

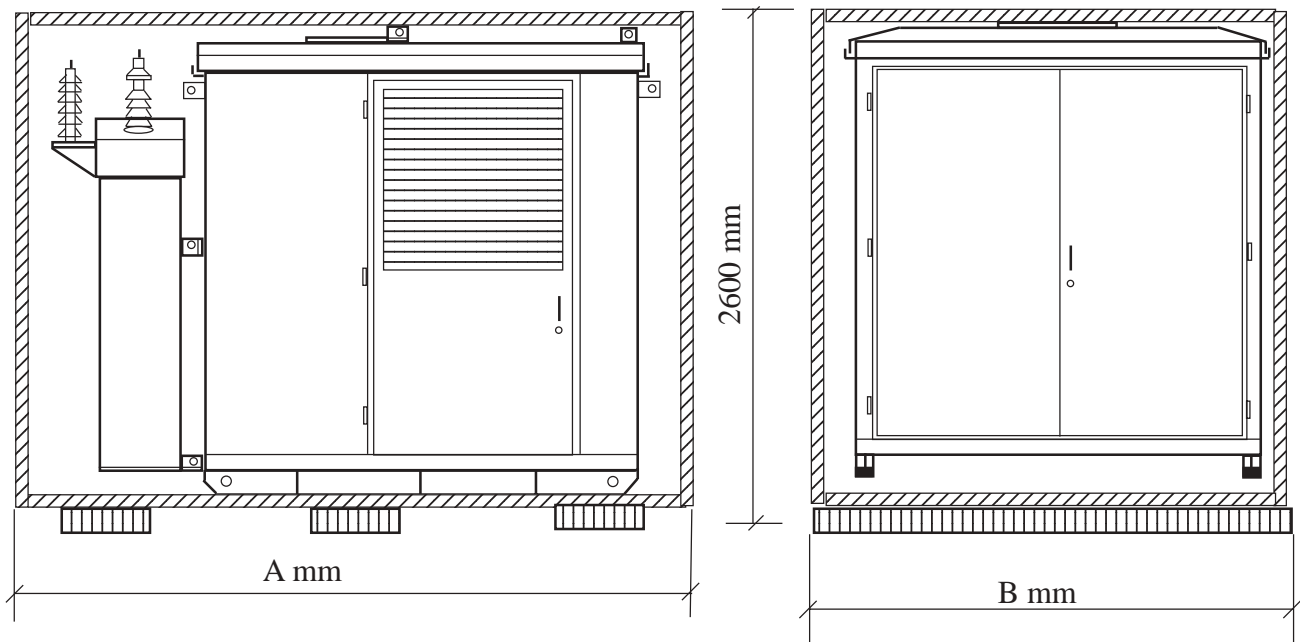

КТП Kv 20/0.4 kV	A	B	Tare
63;100;160;250 kVA	3 300	2 000	2500;2610;2815;3080 kg
400 and 630 kVA	3 700	2 400	3840;4430 kg

