

Transformer Substation RRP 6kV

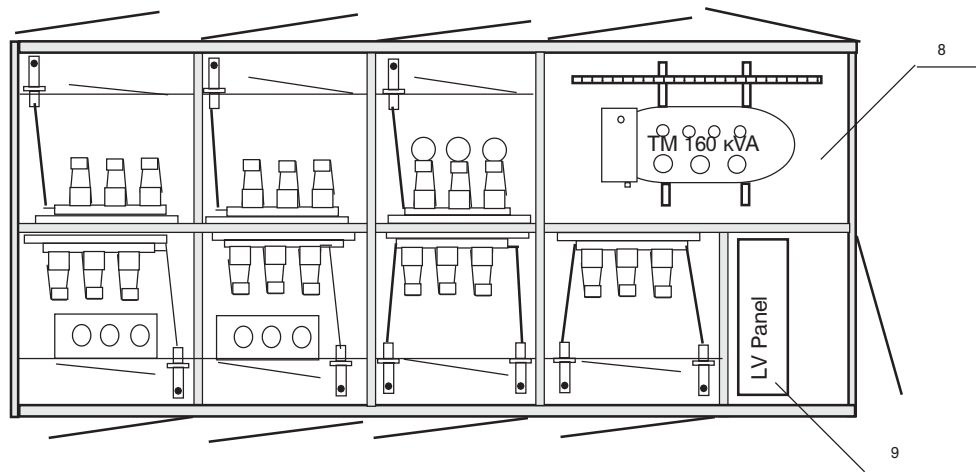

1. Buss bar 50x5 Al 99.9% 400A
 2. Disconnector 10kV/400A 20kA
 3. Circuit breaker 12kV, 630A 25kA
 4. Current transformer 12kV/5/5A
 5. Surge arresters 10/10kA
 6. Disconnector vit eart 10kV/400A 20kA
 7. In/Out
 8. Power Oil Transformer 6/0.4 kV to 250kVA
 9. Distribution Unit TM 160,250
- Area- 11,85 кв.м.**

Single line diagram PPP 6 kV

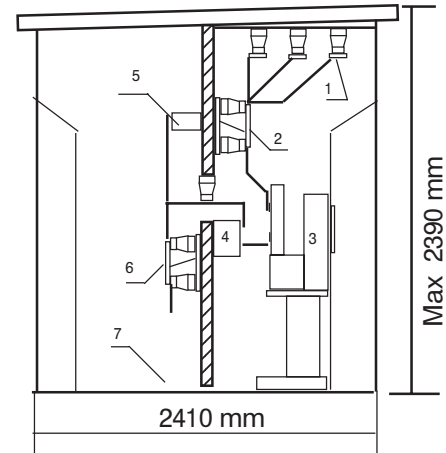
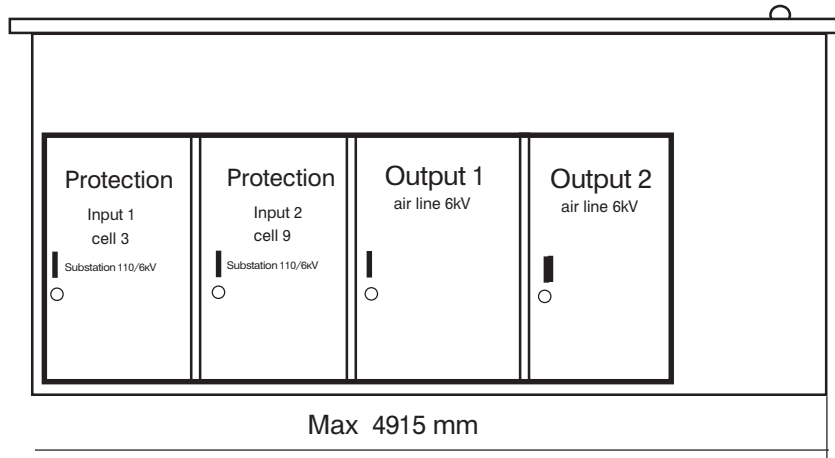